

SM 250

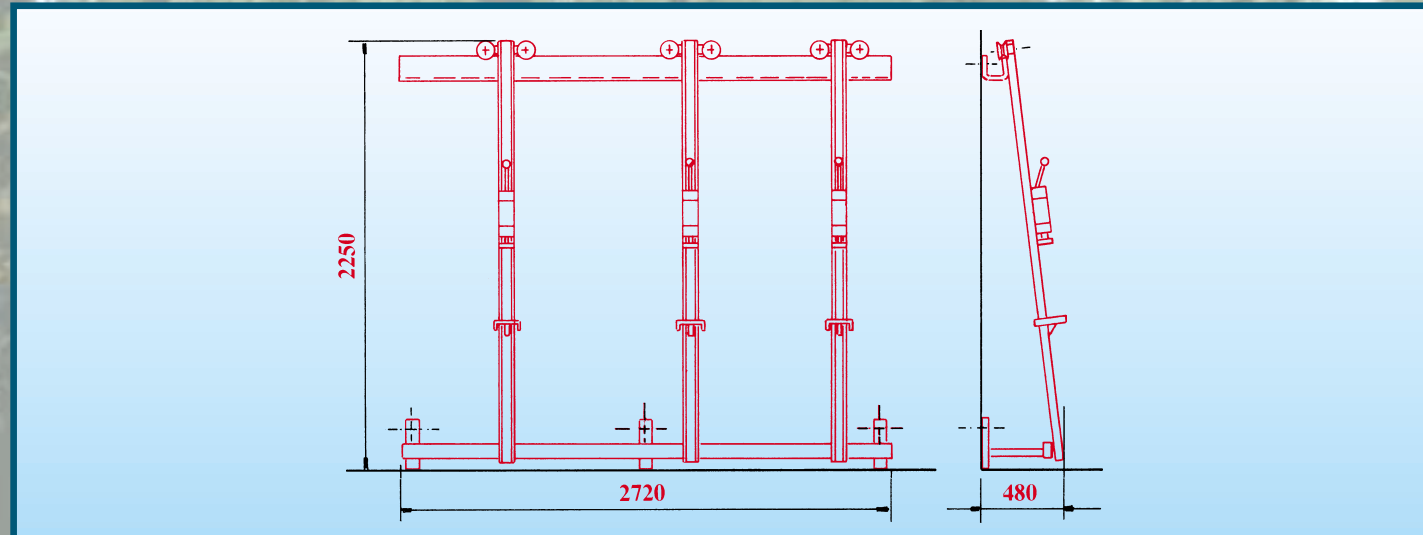

DATI TECNICI		SM 250
Lunghezza utile	mm.	2500
Altezza utile	mm.	1800
Corsa pistone pressore	mm.	60
Spinta massima pompa	kg.	1200
Peso netto	kg.	210
Peso lordo	kg.	235
Dimensioni imballo (Larghezza x Lunghezza x Altezza)	mm.	2750 x 440 x 400
Ingombro (vedi schizzo)	kg.	2200
Equipaggiamento standard: 3 Montanti verticali muniti di pompe manuali e piedini appoggio legno. 1 Pressore frontale manuale.		
Opzionali a richiesta: Montanti verticali supplementari completi di pompa manuale. Pressori frontali manuali. Maggiore capacità di lavoro: lunghezza 3000 mm, altezza 2000 mm.		

DONNEES TECHNIQUES		SM 250
Longueur utile	mm.	2500
Hauteur utile	mm.	1800
Course des cylindres	mm.	60
Poussée des cylindres	kg.	1200
Poids net	kg.	210
Poids brut	kg.	235
Dimensions de l'emballage (Largeur x Longueur x Hauteur)	mm.	2750 x 440 x 400
Encombrement (voir schéma)	kg.	2200
Equipement standard: 3 Montants verticaux équipés avec cylindre manuelle et pied d'appui pour bois. 1 Presseur frontal manuel.		
En option sur demande: Montants verticaux supplémentaires avec cylindre manuelle. Presseurs frontaux manuels. Capacité de travail plus grande: longueur 3000 mm, hauteur 2000 mm.		

TECHNICAL DATA		SM 250
Useful lengths	mm.	2500
Useful heights	mm.	1800
Stroke of the pumps	mm.	60
Max. pump thrust	kg.	1200
Net weight	kg.	210
Gross weight	kg.	235
Packing sizes (Width x Length x Height)	mm.	2750 x 440 x 400
Overall dimensions	kg.	2200
Standard equipment: 3 Vertical beams with hand pumps and timber rests. 1 Front manual pressure bar.		
Optional extra: Additional vertical beams complete with hand pump. Front manual pressure bars. Increased working capacity: length 3000 mm, height 2000 mm.		

TECHNISCHE DATEN		SM 250
Nutzlänge	mm.	2500
Nutzhöhe	mm.	1800
Kolbenhub der Zylinder	mm.	60
Max. Druck der Zylinder	kg.	1200
Nettogewicht	kg.	210
Bruttogewicht	kg.	235
Abmessungen der Verpackung (Länge x Breite x Höhe)	mm.	2750 x 440 x 400
Ausmasse (siehe Skizze)	kg.	2200
Standard Ausrüstung: 3 Vertikalständer komplett mit Zylinder und Holz-Auflagefüße. 1 Handbetätigte Frontrückführung.		
Sonderausrüstung auf anfrage: Zusätzliche Vertikalständer komplett mit Zylinder. Handbetätigte Frontrückführung. Vergrößerung des Arbeitsbereiches: Länge 3000 mm, Höhe 2000 mm.		



42017 NOVELLARA (RE) Italy - Via Provinciale Nord, 237 - Tel. 0522 653545 - Fax 0522 662952
E-mail: info@stromab.com - www.stromab.com

SM 250

STRETTOIO MURALE
CADREUSE À MUR
WALL CLAMPING MACHINE
WANDPRESSE

